

E-Z POUR 200 DIESEL MELTER

WITH PUMP/APPLICATOR

This manual is furnished with each new CRAFTCO E-Z POUR 200 DIESEL MELTER. The manual will help your machine operators learn to run the sealer properly and understand its mechanical functions for trouble-free operation.

Your CRAFTCO E-Z POUR 200 DIESEL MELTER is designed to give excellent service and save maintenance expense. However, as with all specially engineered equipment, you can get best results at minimum costs if:

- (1) You operate your machine as instructed in this manual, and
- (2) Maintain your machine regularly as stated in this manual.

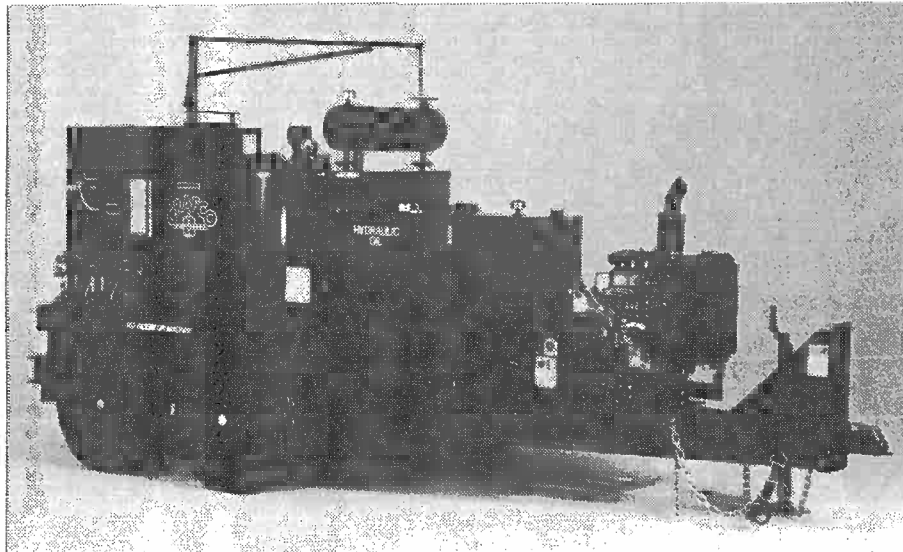

TABLE OF CONTENTS

Safety Precautions.	3
Limited Warranty.	4
Warranty Claim Instructions.	5
Specifications.	6
Introduction.	7
Operation & Start Up.	8
Temperature Control Calibration.	11
Loading Machine.	12
Shutdown & Cleaning.	12
Storing Machine.	12
Trouble Shooting Guide.	13
Burner Trouble Shooting Guide.	14
Service Instructions.	14
Maintenance Instructions.	15
Maintenance Chart.	15-16
Pump Section.	16
Fluids & Lubricants.	17
General Maintenance Items.	18
Instructions for Ordering Parts.	18
Parts List.	19-21
Hydraulic Piping Sequence.	22-24
Diesel Piping Sequence.	24
E-Z Pour 200 Diesel Melter Diagram.	25-26
Control Box Diagram.	26
Hydraulic Piping Diagram.	27
Diesel Piping Diagram.	28
Burner Schematic w/ Flame Shutdown.	29
Wiring With Internal Circuit Breaker.	30

SAFETY PRECAUTIONS

- *High operating temperatures of Sealant & Machine require protective clothing and gloves be worn by operator.
- *Always wear eye protection.
- *Observe all CAUTION & WARNING signs posted on machine.
- *Avoid the entrance of water into any part of the machine. Water will displace heat transfer oil or sealant which could be hazardous to personnel surrounding the machine when it reaches operating temperatures.
- *Avoid bodily contact with hot sealant material or heat transfer oil, serious burns may result.
- *Read Operator Manual thoroughly before operating machine.
- *Make sure operator is familiar with machine operation.
- *Do not operate in closed building or confined areas.
- *Shut-down burner & engine prior to refilling Diesel Tanks.
- *When adding solid material to Sealant tank, stop mixer, lift lid, place material onto lid and close lid before restarting mixer. Hot material could splash and cause serious burns if this procedure is not followed.
- *Keep hands, feet and clothing away from all moving parts.
- *Always keep a fire extinguisher near the unit. Maintain extinguisher properly and be familiar with its use.
- *Do not exceed 525° F. for heat transfer oil temperature.
- *Do not overfill heat transfer oil level. Expansion of oil during heat up could cause overflow. With machine in level position, check oil each day before starting burner, add oil to top mark on dipstick if required (at 70° F.). **Use only recommended heat transfer oil and change after 500 hours of operation or one year, whichever occurs first.**
- *Follow operating instructions for starting and shut-down of burner. Instructions are mounted on control box.
- *Calibrate temperature control prior to initial operation and each 50 hours of operation.
- *Replace any hoses which show signs of wear, fraying or splitting. Be sure all fittings and joints are tight and leakproof.
- *Precaution is the best insurance against accidents.
- *The E-Z Pour 200 Diesel Melter should not be left unattended with burner lit.
- *Tighten all bolts and screws after every 100 hours of operation.
- *CRAFCO, INC. assumes no Liability for an accident or injury incurred through improper use of the machine.

E-Z POUR 200 DIESEL MELTER LIMITED WARRANTY

Crafco, Inc., through its authorized distributor, will replace for the original purchaser free of charge any parts found upon examination by the factory at Chandler, Arizona, to be defective in material or workmanship. This warranty is for a period within 60 days of purchase date, but excludes engine/or components, tires, and battery as these items are subject to warranties issued by their manufacturers.

After 60 days, Crafco, Inc. warrants structural parts, excluding heating system, hydraulic components, material pump and hoses, hot oil pump, applicator valves, and electrical components for a period of (1) one year from date of delivery. Crafco, Inc., shall not be liable for parts that have been damaged by accident, alteration, abuse, improper lubrication/maintenance, normal wear, or other cause beyond our control.

The warranty provided herein extends only to the repair and/or replacement of those components on the equipment covered above and does not cover labor costs. The warranty does not extend to incidental or consequential damages incurred as a result of any defect covered by this warranty.

All transportation and labor costs incurred by the purchaser in submitting or repairing covered components must be bore by the purchaser.

Crafco, Inc., specifically disavows any other representation, warranty or liability related to the condition or use of the product.

Warning - Use of replacement parts other than genuine Crafco parts may impair the safety of reliability of your equipment and nulifies any warranty.

CRAFCO, INC.

WARRANTY CLAIM INSTRUCTIONS

Please follow the instructions stated below when calling in a Warranty Claim. Failure to follow these procedures may be cause to void the warranty.

- (1) Call your local Crafcoc Distributor. If you do not know who your local distributor is, call a Crafcoc Customer Service Representative, (Toll Free 1-800-528-8242) for name, location and telephone number.
- (2) On contacting the Distributor, be prepared to identify the machine type, model number and serial number, also the date of purchase if available.
- (3) Should the cause of the malfunction be a defective part, the Distributor will advise you of the procedure to follow for a replacement.
- (4) The warranty is valid only for parts which have been supplied or recommended by Crafcoc, Inc.

If you have any additional questions regarding warranty repairs and parts, please do not hesitate to call toll free 1-800-528-8242.

CRAFCO, INC.
6975 WEST CRAFCO WAY
CHANDLER, AZ 85226
(602) 276-0406
Toll Free 1-800-528-8242

SPECIFICATIONS

Vat Capacity	200 Gallons
Melt Capacity	150 Gallons/Hour
Heat Transfer Oil Required	27 Gallons at 70° F.
Tank Construction	Double Boiler Type
Tank Opening Size	16" x 24"
Maximum Heat Input	Diesel, Burner - 275,000 BTU
Burner & Temperature Control	Thermostatic
Engine - ISUZU Model 3KC1	3 Cylinder 23 HP @ 3600 rpm
Drive Mechanism	All Hydraulic with infinite speed forward & reverse action
Mixer	Full sweep mixer with 2 horizontal paddles
Axle (2)	Dual - 3,500 lbs. Capacity
Tires (4)	185R-14 lbs. capacity each 1850# @ 65 PSI
Dry Weight	Approximately 4,000 lbs.
Diesel Tank	33 Gallons

E-Z POUR 200 DIESEL MELTER OPERATING INSTRUCTIONS

INTRODUCTION

The CRAFCO E-Z Pour 200 Diesel Melter was developed to melt CRAFCO Brand Sealants. However, it will work equally well with all road asphalts and federal specification crack or joint sealants.

DO NOT operate machine without reading operator's manual and being thoroughly familiar with controls:

1. Fill engine fuel tank with diesel fuel (use #1 in cold weather, #2 in warm weather).
2. Check engine crankcase oil (refer to Engine Operator's Manual).
3. Check hydraulic fluid level, at ambient temperature. Add fluid if necessary to bring fluid to correct level.
4. Check heat transfer oil supply. Check level at ambient temperature, machine level. At 70° F., oil should be at the top mark. **DO NOT** overfill, or spillage may occur when machine reaches operating temperature.
5. All valves should be in closed position and temperature control box set at "OFF".
6. Applicator hose can be kept warm and ready for use by storing in heating chamber before using machine. close heating doors after hose and wand have been coiled in chamber.
7. Check temperature control calibration.

OPERATION OF CRAFCO E-Z POUR 200 DIESEL MELTER/APPLICATOR

MACHINE START UP

TO START

1. Fully open the Damper Vent, (Pg. 9 item A).
2. Set Temperature Dial to "OFF".
3. Start engine.
4. Turn Temperature Dial to desired temperature setting.

CAUTION:

If Burner does not ignite the first time, turn temperature dial to off. Turn temperature dial to desired setting. Burner should ignite. If burner still does not ignite, determine cause of malfunction (see Trouble Shooting Guide).

5. Allow the heating oil to continue to heat. When sealant material reaches a liquid state, engage the agitator by moving the agitator lever either forward or backward. If agitator does not move, allow material to heat longer. Jamming of agitator shaft causes hydraulic oil to over heat and machine damage could occur.
6. When sealant reaches correct application temperature, open main tank valve (Pg. 9 item E), open recirculation valve (Pg. 9 item B) and close applicator valve (Pg. 9 item C). Put sealant pump in reverse (Suction) mode. When pump turns freely, reverse sealant pump flow (Discharge) (Pg. 9 item D). This circulates sealant back into tank.
7. Check the sealant temperature in line (Pg. 9 item F). This indicates the temperature of sealant flowing through lines.
8. When application of sealant is desired, remove the hose from the rear of machine. Attach hose to hand applicator. Be sure to hand tighten only. Place applicator in rear tank opening, with the hand wand valve in the **ON** positions.
9. Open applicator valve (Pg. 9 item C).
10. Close the ricirculation valve (Pg. 9 item B). **IMPORTANT:** Adjust the valve to get the desired amount of flow from the applicator wand given your applicator needs. You do not need to close the valve all the way for application. If material does not flow from wand, the hose may need to be warmed. Heat hose by placing in heating chamber to liquify sealant in hose, then repeat procedure.
11. Extreme care should be taken when changing or installing applicator tips. If the material is hot the material pump **must** be put in the "Suction" mode. This will insure against hot material pumped from wand. **Sealant material is hot and can cause skin burns.**
12. To apply sealant to joint, remove hand applicator from rear tank opening. **Make sure** the hand wand valve is closed. When applicator wand is over joint, open hand valve and apply sealant.
13. To prevent hose from cooling, place the applicator wand in the rear tank opening when not to be used for 2 minutes or more. Always close hand wand prior to inserting wand in tank opening. Open hand valve to recirculate back into tank and keep hose warm.

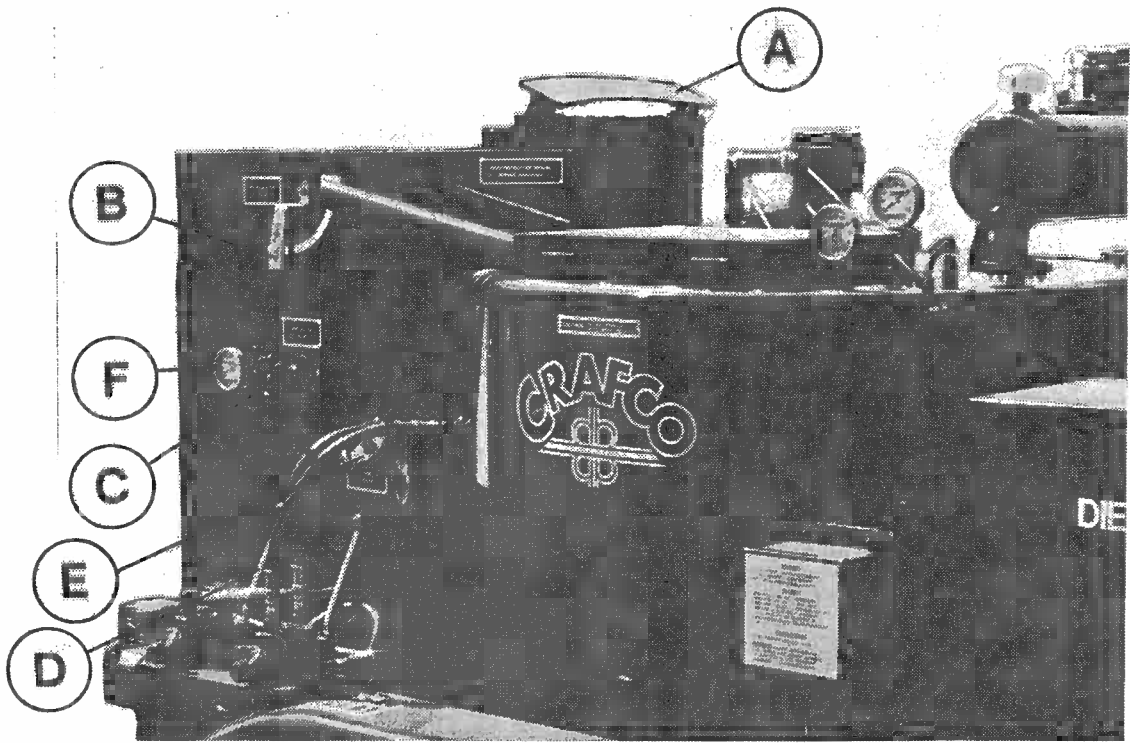

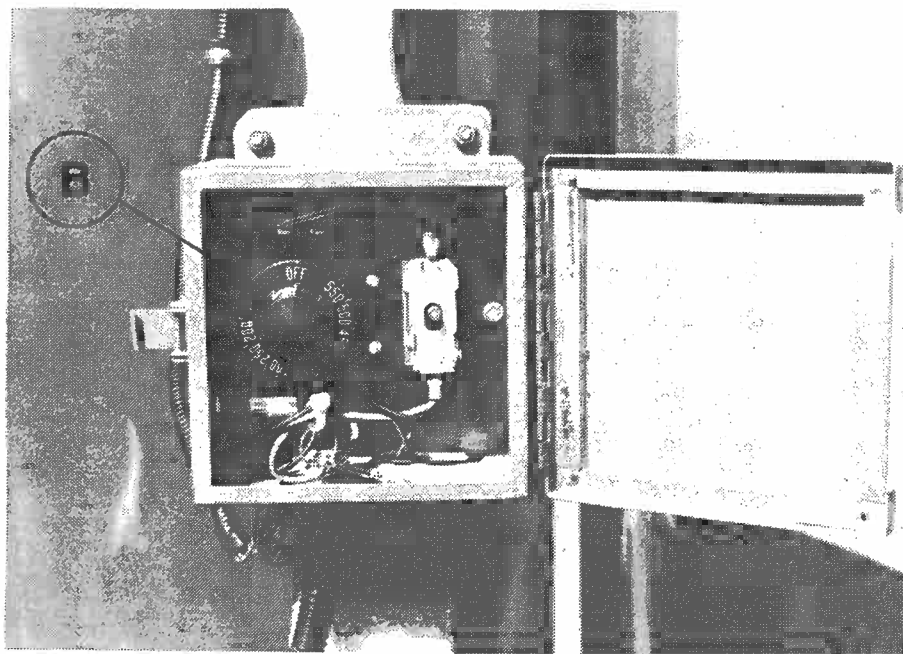
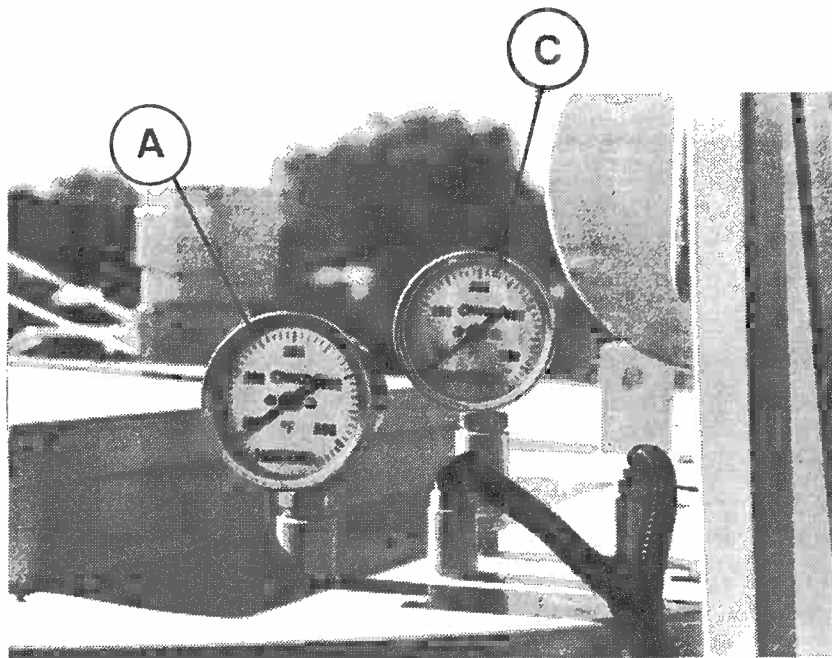

CHECKING TEMPERATURE CONTROL CALIBRATION

The temperature control system is calibrated at the factory during testing; however, it is good practice to check the calibration when the machine is first put into operation. And also checked again periodically. (Each 50 hours of operation is recommended.) The gauge (Pg.10 item A) registers the actual temperature of the heat transfer oil and it should coincide with the temperature control hand knob setting (Pg. 10 item B).

To check the calibration, the following procedure must be followed - at ambient temperature, check heat transfer oil level, using dipstick. Start up the burner. Set temperature control hand knob at about 250° F. Leave burners on until 200° F. registers on the temperature gauge. Slowly turn the temperature control hand knob down until a click is heard and/or the burner shuts off. If the temperature control hand knob, at this point, reads differently than the temperature gauge, recalibration is required.

RECALIBRATING THE TEMPERATURE CONTROLS

To recalibrate the temperature control, set the temperature control knob to 200° F. When the burner shuts off, carefully pull the hand knob off the spindle. Be careful not to move the spindle during this operation. With a jeweler's screwdriver (or the flattened end of a paper clip) turn the adjusting screw inside the spindle *counterclockwise* to increase temperature or *clockwise* to decrease temperature (1/8 turn will change the temperature 15° F. to 20° F.). Carefully replace hand knob. Both the hand knob and the temperature gauge should now read approximately 200° F.

CAUTION:

Extreme care must be used when operating this equipment. Safety is the result of being careful and paying attention to details. Remember the diesel flame is about 2200° F. Certain exposed parts of this machine, when operating, reach 500° F.; the sealant as high as 400° F. and the hydraulic oil may reach 200° F. Always wear protective clothing and eye protection. Be sure that all joints and fittings are tight and leakproof. Immediately replace any hose which shows any signs of wear, fraying or splitting. Tighten all bolts on all flanges after 100 hours. Tighten ALL bolts, nuts and screws every 250 hours.

LOADING MACHINE

When loading solid material into the sealant tank, the mixer must be momentarily stopped, the lid lifted, the material placed on the lid and the lid closed again before the mixer is restarted. Following this procedure will prevent the hot material from splashing and causing serious burns to personnel.

The solid materials must be added at intervals which will allow the mixer to rotate without jamming. If blocks of material are fed in too quickly, jamming will result and slow down the melting process. Always try to maintain a melted material level at least 6" above the horizontal portions of the mixer.

SHUTDOWN AND CLEAN-OUT PROCEDURE

1. Turn temperature dial to off.
2. Move mixer control valve to **OFF** position.
3. Close recirculation valve.
4. Put material pump in suction mode. With hand applicator valve open, disconnect wand and return hose to heat chamber. Close applicator valve. Open recirculation valve. Close main tank valve.
5. Return material pump control valve to **OFF** position.
6. Turn off engine.
7. Return wand to heat chamber.

STORING MACHINE

The E-Z Pour 200 should be stored with the trailer tongue in an elevated position. This will allow the moisture condensation to settle to the bottom rear of the heat transfer oil tank, above the drain plug. After extended periods of time, the water can be drained by removing the plug and replacing it when all water is displaced.

CAUTION: If there is any suspicion that moisture is still present after draining, warm heat transfer oil to 300° F. for 2 or 3 hours to evaporate any moisture.

TROUBLE SHOOTING GUIDE

PROBLEM	CAUSE	REMEDY
Mixer will not rotate.	Sealant temperature too low.	Continue to heat material.
	Too many blocks placed at one time.	Continue to heat material & try reversing mixer.
	Inadequate hydraulic flow/pressure.	Check hydraulic fluid level. Reset pressure/check flow if necessary.
Material pump will not turn.	Material in tank not to operating temperature.	Continue heating material.
	Inadequate hydraulic, flow/pressure.	Check hydraulic fluid level. Reset pressure/check flow as necessary.
	Material pump damaged or foreign object lodged in pump.	Replace/Remove.
Sealant will not recirculate back into tank through recirculation valve.	Material in tank not to correct temperature.	Continue heating material.
	Drain valve closed.	Open valve.
	Material still cold in suction line. Recirculation valve closed.	Make sure compartment temperature is adequate to melt material. Open valve.
Sealant material flows through recirculation valve but will not flow through application hand wand.	Application valve not open.	Open valve.
	Recirculation valve still open or damaged internally.	Close valve or replace.
	Hose/wand still cold.	Leave in chamber until hot.
When applying sealant it stops flowing from applicator wand.	Hand applicator valve was left in off position too long.	Heat hose by placing in heat chamber to liquify sealant.
	Too many blocks of material added to tank. Cold material entered pump & stopped flow.	Heat hose by placing in heating chamber to liquify sealant.
	Tank fluid level too low for material to flow into pump.	Continue heating material until more liquid material is available.
Pump rotates, but will not pump material.	Material pump worn or damaged.	Replace/Repair.
	Pump rotating in wrong direction.	Reverse control lever.
	Foreign object lodged in inlet line to pump.	Dislodge by reversing pump or disassemble inlet line.
	Material cold, inlet still solid.	Continue to heat material.
	Block of sealant over drain.	Dislodge by reversing mixer and pump.
Slow heat up of sealant.	Build up of coked or crystallized material on inside of material tank.	Allow machine to cool. Remove deposits and flush with solvent.
	Burner not operating.	See Burner Trouble Shooting Guide page 14.
	Low heating oil level.	Make sure fluid level is correct.
	Low heating oil temperature.	Set at recommended temperature.

BURNER TROUBLE SHOOTING GUIDE

PROBLEM	CAUSE	SOLUTION
Burner Blower runs but Burner will not light.	1) Clogged fuel nozzle.	1) Clean/or Replace.
	2) No fuel in tank, valve at tank shut off, clogged filter or jellied fuel.	2) Add fuel if necessary open valve, use fuel for anticipated weather.
	3) Ignitor wires loose, dirty ignitors, faulty transformer.	3) Check for loose wiring, clean and adjust ignitors, replace transformer if faulty.
	4) Faulty fuel solenoid, loose wire.	4) Replace solenoid if necessary tighten all connections.
	5) Fuel pump at burner needs bleeding.	5) Open bleeder until fuel runs clear, tighten.
Excess Smoke in Heat Compartment.	1) Air Vent incorrectly set.	1) Set at 5.
	2) Blower Motor not running at correct speed.	2) Charge Battery by starting engine.
Make sure engine is running so battery is fully charged.		
Blower motor will not turn at correct speed or Burner will not ignite.	1) High limit switch.	1) Check or replace.
	2) Wires at temperature control box loose or broken.	2) Check connections or tighten, replace if necessary.
	3) Battery low, alternator belt loose, alternator failure.	3) Recharge battery, tighten belt, check/replace alternator if necessary.
	4) Loose/Broken Battery Cable.	4) Tighten/Replace.
	5) Engine not running.	5) Charge battery by starting engine.
	6) Thermostatic Control faulty.	6) Replace.
Burner will not shut down at set temperature.	1) Thermostatic control faulty or needs recalibration.	1) Recalibrate or replace if necessary.

SERVICE INSTRUCTIONS

1. Conduct a general inspection of your machine at least once a week. Replace all worn or damaged parts, make any necessary adjustments and tighten all loose nuts or screws.
2. Keep regular replacement items in stock for emergency repairs, to avoid costly "down" time. Refer to general maintenance items, page 18.
3. Watch for leaks - tighten packing on pumps as necessary.
4. Clean machine externally periodically. Check with sealant manufacturer for recommendation.
5. Follow recommended maintenance procedures on maintenance chart.

MAINTENANCE INSTRUCTIONS

ENGINE:

Check engine oil daily. Change after the first 50 hours of operation and change every 100 hours thereafter.

Change Oil Filter initially at 50 hours, every 300 hours thereafter.

See engine owners manual for additional operating and maintenance instructions.

HYDRAULIC SYSTEM:

Check hydraulic fluid daily. Change hydraulic filter after first 10 hours of operating and every 250 hours thereafter. Change hydraulic fluid every 500 hours of operation.

WHEEL BEARINGS:

Repack wheel bearings every 24,000 miles or every two years, using a good grade of bearing grease.

TONGUE JACK:

Lubricate tongue jack, using a good grade of bearing grease.

SEALANT PUMP:

Lubricate outboard bearings using a good grade of bearing grease. Adjust pump packing periodically. A slight drippage (several drops per minute) should be allowed. Refer to Pump Section for details. See page 16.

MAINTENANCE CHART

LOCATION	PROCEDURE	HOURS			
		Daily	50	100	500
Engine Check Oil Level	Check daily.	*			
Other Engine Maintenance	See Isuzu Operating and Maintenance Instructions.				
Battery	Check Water Level weekly.				
Pump Packing	Tighten as required. Drip should be several drops/ per minute.		*		
Pump Outboard Bearing	Lubricate using a good grade of bearing grease.		*		
Heat Transfer Oil	Check (every 8 hours).		*		
	Change	after 500 hours or 1 year.			

MAINTENANCE CHART *continued on page 16*

MAINTENANCE CHART *continued*

LOCATION	PROCEDURE	HOURS			
		Daily	50	100	500
Hydraulic Oil Return line filter	First change (10 hours).	*			
	Subsequent changes (250 hours).			*	
Hydraulic Oil	Check Oil (Daily).	*			
	Change Oil (every 500 hours).				*
	For Proper Oil, see recommended fluids & Lubricants, page 17.				
Wheel Bearings	Clean & repack - using good grade of bearing grease.	Every 24,000 miles or every two years.			
Tongue Jack	Grease, using good grade of bearing grease.	Once a Year.			
Air Compressor	See Air Compressor Manual.				

**PUMP SECTION
PACKING INSTRUCTIONS**

Operate the pump under normal conditions and, after a short run-in period, examine packing for leakage. If leakage is excessive tighten locknuts evenly until there is only slight leakage from the packing rings. This slight leakage is a necessary and normal condition for packing and allows for expansion and proper seating.

NOTE: WHERE LIQUID IS BEING HANDLED THAT IS HAZARDOUS OR VOLATILE, FULL PRECAUTIONS SHOULD BE TAKEN DURING THE RUN-UP PERIOD.

To replace packing remove key, two nuts and clips, packing gland and packing rings. (Packing hooks are commercially available to assist in removing the packing rings). Clean the shaft and adjacent parts. Examine the shaft, if it is excessively worn or scored, replacement of shaft or pump may be necessary.

Insert packing rings, making sure the joints are staggered 180 degrees. Use split ring bushings to seat each ring before adding the next ring. The rings must not be tamped or seated in place too tightly. When the packing box is sufficiently full to allow entry of the packing gland (about ¼") reassemble the packing gland, clips and nuts. Draw up evenly on the packing gland to assure proper seating of the packing, and then loosen nuts about ½ turn. Do not cock the packing gland. (This could cause binding or heating of the shaft).

RECOMMENDED FLUIDS & LUBRICANTS

APPLICATION	RECOMMENDED	FULL POINT
Engine Oil	Refer to Isuzu Engine Operating Manual.	
Diesel	#1 Cold Climate #2 Warm Climate	30 Gal.
Hydraulic Oil	RONDO OIL-HD-68 Texaco	28 Gal.
Heat Transfer Oil		

The following is a list of suitable Heat Transfer Oils to be used in CrafcO equipment.

<u>Producer</u>	<u>Product Name</u>	<u>Product No.</u>
Texaco	Regal	R&O 68
Gulf	Harmony	68
Shell	Thermia	"C"
Exxon	Teresstic	68
Phillips	Magnus	68
Chevron USA	Heat Transfer Oil #1	
Conoco	Dectol R&O	68
Union Oil	Turbine Oil	68

WARNING

The Heat Transfer Oil in this machine is a grade that has been tested and recommended by CRAFCO, Inc. The addition of any grade of oil not specifically recommended by CRAFCO, Inc. shall be cause for the voidance of all warranties.

All oils subjected to high temperatures deteriorate with time and lose many of their characteristics. Tests conducted by CRAFCO, Inc. have determined that for best results and safety, the Heat Transfer Oil in this machine must be drained and replaced with CrafcO, Inc. recommended oil after five hundred (500) hours of operation or one (1) year, whichever occurs first.

GENERAL MAINTENANCE ITEMS

RECOMMENDED QUANTITY	DESCRIPTION	PART NO.
1 Set	Packing, Sealant Pump	29990
1	Sealant Hose Assembly	27009
1	Engine Oil Filter	41869
1	Engine Fuel Filter	41867
1	Hydraulic Filter	22071
1	Air Filter	41868

INSTRUCTION FOR ORDERING PARTS

Parts may be ordered from your local CRAFCO distributor or directly from CRAFCO, Inc. if a distributor is not available in your area. When ordering parts, give the following information:

1. Part Number
2. Machine Model
3. Serial Number from Name Plate

Write or telephone:

CRAFCO, INC.
6975 WEST CRAFCO WAY
CHANDLER, AZ 85226
(602) 276-0406
Toll Free: 1-800-528-8242

PARTS LIST

ITEM NO.	DESCRIPTION	QTY.	PART NO.
1.	Tire And Wheel Assembly	4	41743
2.	Axle Assembly with Springs	2	41085
3.	Rocker Arm	2	23088
4.	Shackle Tie Plate	8	23075
5.	Shackle Bolt	14	23100
6.	Shackle Nut	14	23105
7.	Fender - L.H. Assembly	1	41170
8.	Fender - R.H. Assembly	1	41171
9.	5/16 - 18 x 1 Bolt	8	28716
10.	Fender Washer	8	28681
11.	5/16 - 18 Locknut	8	28525
12.	Tail Light R.H.	1	24022
13.	Tail Light L.H.	1	24023
14.	¼ Flat Washer	4	28670
15.	¼ Lockwasher	4	28645
16.	¼ - 20 Hex Nut	4	28500
17.	Tongue Jack, Side Mount	1	23097
18.	Jack Swivel Bushing	1	23096
19.	Breakaway Switch Unit	1	23117
20.	23 H.P. Diesel Engine	1	41860
21.	Isomount	4	41872
22.	Solenoid	1	39602
23.	Hydraulic Pump	1	41193
24.	½ - 13 x 1 ¼ Bolt	2	28761
25.	½ Lockwasher	2	28649
26.	Diesel Storage Tank	1	41835
27.	Hydraulic Reservoir	1	41833
28.	Air Breather	3	26025
29.	Filler Cap	1	26035
30.	Dipstick Assembly	1	41162
31.	Hydraulic Filter	1	22070
32.	1 x 90° Pipe Elbow	1	28210
33.	1" Close Nipple	1	28005
34.	1 x 90° Street Elbow	1	28240
35.	14 Volt Burner	1	41891
36.	Oil Burner Nozzle	1	41881
37.	Blower Motor	1	41890
38.	Fuel Solenoid	1	41888
39.	Agitator Control Valve	1	41093
40.	Material Pump Control Valve	1	41092
41.	¼ - 20 x 1 ½ Bolt	6	28704
42.	¼ Lock washer	6	28645
43.	¼ Hex Nut	6	28500
44.	Flow Divider	1	41573
45.	Mounting Plate	1	40029
46.	Pipe Spacer	4	40030
47.	3/8 - 16 x 2 ½ Bolt	4	28736
48.	3/8 Lockwasher	4	28647
49.	Agitator Motor	1	22310

ITEM NO.	DESCRIPTION	QTY.	PART NO.
50.	3/8 - 16 x 1" Bolt	4	28731
51.	3/8 Lockwasher	4	28647
52.	Agitator Shaft Assembly	1	41190
53.	1-5/8 Flat Washer	2	28682
54.	Paddle Assembly	2	41070
55.	3/8 - 16 x 1 Bolt	8	28731
56.	3/8 Lockwasher	8	28647
57.	3/8 - 16 Locknut	8	28526
58.	1/2 Pipe Coupling	2	28178
59.	24" Temperature Gage	1	41243
60.	12" Temperature Gage	1	40078
61.	3/8 Pipe Coupling	2	28177
62.	Stuffing Box	2	25203
63.	Flange Assembly	2	41153
64.	Overflow Tank	1	41002
65.	4 Hole Flange Gasket	2	29051
66.	3/8 - 16 x 1 Bolt	8	28731
67.	3/8 - 16 Locknut	8	28538
68.	Dipstick Assembly	1	41199
69.	9" Temperature Gage	1	25057
70.	Flanged Nipple Assembly	3	22030
71.	Flanged Gasket - 6 Hole	4	29050
72.	3/8 - 16 x 1 Bolt	24	28731
73.	3/8 - 16 Locknut	24	28538
74.	Pipe Assembly - Upper	1	41678
75.	Recirculation Valve	1	41246
76.	Flange Tee	1	41677
77.	Double Elbow Assembly	1	41134
78.	2 1/2" Temperature Gage	1	25050
79.	3/8 Close Nipple	1	28002
80.	3/8 Ball Valve	1	29202
81.	3/8 x 90° Street Elbow	1	28237
82.	3/8 Pipe Plug	1	28282
83.	2" Gate Valve	1	29270
84.	2" x 8" Pipe Nipple	1	28110
85.	2 x 90° Pipe Elbow	2	28213
86.	Cross Feed Pipe	1	41291
87.	2 x 1 Reducing Bushing	1	28358
88.	2" Clevis Hanger	1	26078
89.	Roper Material Pump	1	41101
90.	1/2 - 13 x 1 3/4 Bolt	4	28763
91.	1/2 Lockwasher	4	28649
92.	1/2 - 13 Hex Nut	4	28504
93.	1/2 Flat Washer	4	28674
94.	Hydraulic Motor	1	22027
95.	3/8 - 16 x 3/4 Bolt	4	28730
96.	3/8 Lockwasher	4	28647
97.	Chain Sprocket	2	26002
98.	Dual Sprocket Chain	1	26016
99.	Connecting Link	1	26030

ITEM NO.	DESCRIPTION	QTY.	PART NO.
100.	Chain Guard	1	41140
101.	5/16 Lockwasher	1	28646
102.	5/16 - 18 Hex Nut	1	28501
103.	Material Pump Suction Line	1	41133
104.	Pipe Assembly Material Suction	1	41131
105.	3" Flanged Gate Valve	1	29292
106.	Drain Pipe Ext.	1	41039
107.	Gasket - 8 Hole	2	29060
108.	3/8 - 16 x 1 Bolt	16	28731
109.	3/8 - 16 Locknut	16	28538
110.	Valve Handle Ext.	1	41268
111.	Blind Flange	1	29161
112.	2½ Flange Gasket	2	41043
113.	3/8 - 16 x 1" Bolt	12	28731
114.	3/8 Locknut	12	28538
115.	Flange Assembly - Pour Spout	1	41279
116.	2" Oil Gate Valve	1	29280
117.	Hot Oil Circulating Pump	1	41280
118.	5/16 - 18 x ¼ Bolt	2	28714
119.	5/16 Lockwasher	2	28646
120.	Hydraulic Motor	1	22302
121.	¼ - 28 x 5/8 Bolt	3	28850
122.	¼ Lockwasher	3	28645
123.	½" Bore Coupling Half	1	41180
124.	5/8" Bore Coupling Half	1	41695
125.	Spider For Coupling	1	41182
126.	Male/Female Swivel	2	27048
127.	Sealant Hose Assembly	1	27009
128.	Handle Assembly with Valve	1	41208
129.	Handle Assembly	1	27080
130.	1" Ball Valve	1	29240
131.	1 x ¾ Reducing Bushing	1	28351
132.	¾ x 8 Pipe Nipple	1	28100
133.	Hand Wand Assembly	1	41629
134.	Sealing Tip Assembly	1	27171
135.	Control Box Assembly	1	25286
136.	Indicator Light	1	24140
137.	Rubber Grommet	1	26075
138.	Manual Reset Temperature Probe	1	25240
139.	#6 - 32 x ½ Screw	2	28838
140.	#6 - 32 Nut	2	28839
141.	Electric Thermostat 550°	1	25276
142.	#6 x 3/8 Stl. Thread Forming Screw	2	28832
143.	Temperature Dial	1	25220
	PARTS NOT ILLUSTRATED		
	Battery Box Cover	1	24002
	Battery Cable 38"	1	24015
	Circuit Breaker	1	31512
	Battery Cable 20"	1	32602
	Hour Meter	1	24076

HYDRAULIC PIPING SEQUENCE E-Z POUR 200 DIESEL MELTER WITH PUMP APPLICATOR

1. HYDRAULIC RESERVOIR TO HYDRAULIC PUMP (SUCTION)		
1	29814	90° Elbow Adaptor
1	29572	Hydraulic Hose Assembly 5/8 x 36" Long
1	29824	90° Elbow Adaptor - "O" Ring

2. HYDRAULIC PUMP TO FLOW DIVIDER VALVE ("IN" PORT)		
1	29821	Straight Adaptor - "O" Ring
1	22110	Hydraulic Hose Assembly 1/2 x 27" Long
1	29806	Bulkhead Elbow
1	29807	Bulkhead Locknut
1	41123	Tube Assembly (Press.)
1	29805	Bulkhead Connector
1	29807	Bulkhead Locknut
1	29815	Pipe Swivel Connector
1	28348	Reducing Bushing 3/4 x 1/2

3. FLOW DIVIDER VALVE ("PB" PORT) TO MATERIAL VALVE ("IN" PORT)		
1	28348	Reducing Bushing 3/4 x 1/2
1	29841	Straight Adaptor
1	40187	Hydraulic Hose Assembly 3/8 x 18" Long
1	29876	90° Elbow Adaptor
1	28348	Reducing Bushing 3/4 x 1/2

4. MATERIAL VALVE ("OUT" PORT) TO HYDRAULIC FILTER (RETURN)		
1	41090	Tube Assembly (Return)
1	29806	Bulkhead Elbow
1	29807	Bulkhead Locknut
1	29567	Hydraulic Hose Assembly 1/2" x 41" Long
1	40314	Straight Adaptor
1	28351	Reducing Bushing 1 x 3/4
1	28240	1 x 90° Street Elbow

5. HYDRAULIC FILTER ("OUT" PORT) TO HYDRAULIC RESERVOIR		
1	28240	1 x 90° Street Elbow
1	28005	1" Close Nipple
1	28210	1 x 90° Pipe Elbow

6. FLOW DIVIDER ("REG" PORT) TO MIXER VALVE ("IN" PORT)		
1	28347	Reducing Bushing 3/4 x 3/8
1	29872	90° Elbow Adaptor
1	40012	Hydraulic Hose Assembly 3/8 x 24" Long
1	29872	90° Elbow Adaptor
1	28347	Reducing Bushing 3/4 x 3/8

7. MIXER VALVE ("OUT") PORT TO HYDRAULIC MOTOR FOR H.O. PUMP (REAR PORT)		
1	28347	Reducing Bushing ¾ x 3/8
1	29872	90° Elbow Adaptor
1	40012	Hydraulic Hose Assembly 3/8 x 24" long
1	40311	Straight Adaptor "O" Ring

8. HYDRAULIC MOTOR FOR H.O. PUMP (FRONT PORT) TO TEE IN LINE 4.		
1	40311	Straight Adaptor "O" Ring
1	40187	Hydraulic Hose assembly 3/8 x 18" long
1	29809	Reducer 5/8 to 3/8 Tube
1	29810	Tube Nut

9. MATERIAL VALVE ("INBOARD" PORT) TO HYDRAULIC MOTOR FOR MATERIAL PUMP ("INBOARD PORT")		
1	29841	Straight Adaptor
1	29570	Hydraulic Hose Assembly 3/8 x 34" long
1	22029	Straight Adaptor

10. MATERIAL VALVE ("OUTBOARD" PORT) TO HYDRAULIC MOTOR FOR MATERIAL PUMP ("OUTBOARD" PORT)		
1	29841	Straight Adaptor
1	29570	Hydraulic Hose Assembly 3/8 x 34" long
1	22029	Straight Adaptor

11. MIXER VALVE ("INBOARD" PORT) TO HYDRAULIC MOTOR FOR MIXER (L.H. PORT)		
1	29841	Straight Adaptor
1	40187	Hydraulic Hose Assembly 3/8 x 18" long
1	29808	Tube Union
1	41155	Tube Assembly - L.H.
1	22029	Straight Adaptor

12. MIXER VALVE ("OUTBOARD" PORT) TO HYDRAULIC MOTOR FOR MIXER (R.H. PORT)		
1	29841	Straight Adaptor
1	40187	Hydraulic Hose Assembly 3/8 x 18" long
1	29808	Tube Union
1	41156	Tube Assembly - R.H.
1	22029	Straight adaptor

13. HOT OIL TANK (R.H. PORT) TO HOT OIL PUMP (FRONT PORT) - SUCTION		
1	28178	½ Pipe Coupling
1	29844	Straight Adaptor
1	41060	Tube Assembly
1	29844	Straight Adaptor

14. HOT OIL PUMP (REAR PORT) TO MATERIAL PUMP (TOP PORT)		
1	29844	Straight Adaptor
1	41061	Tube Assembly
1	40316	Straight Adaptor

15. MATERIAL PUMP (TOP PORT) TO HOT OIL TANK (L.H. PORT)		
1	40316	Straight Adaptor
1	41062	Tube Assembly
1	29844	Straight Adaptor
1	28178	½ Pipe Coupling

DIESEL PIPING SEQUENCE E-Z POUR 200 MELTER WITH PUMP APPLICATOR

1. DIESEL FUEL TANK TO DIESEL FUEL PUMP		
1	28340	Reducing Busing ¼ x 1/8
1	32118	Fuel Valve with Screen
1	29590	Fuel Hose ¼ x 80" long
2	26080	Gear Clamp

2. DIESEL FUEL PUMP TO FUEL FILTER		
(Supplied With Engine)		

3. FUEL FILTER TO DIESEL BURNER		
1	29591	Fuel Hose ¼ x 65" long
2	26080	Gear Clamp
1	29831	Tube Adaptor
1	29870	Elbow Adaptor

4. DIESEL ENGINE TO TANK (RETURN)		
1	29592	Fuel Hose 3/16 x 80" long
2	26080	Gear Clamp
1	26790	1/8" Straight Inv. Flare Puch-On
1	29870	Elbow Adaptor

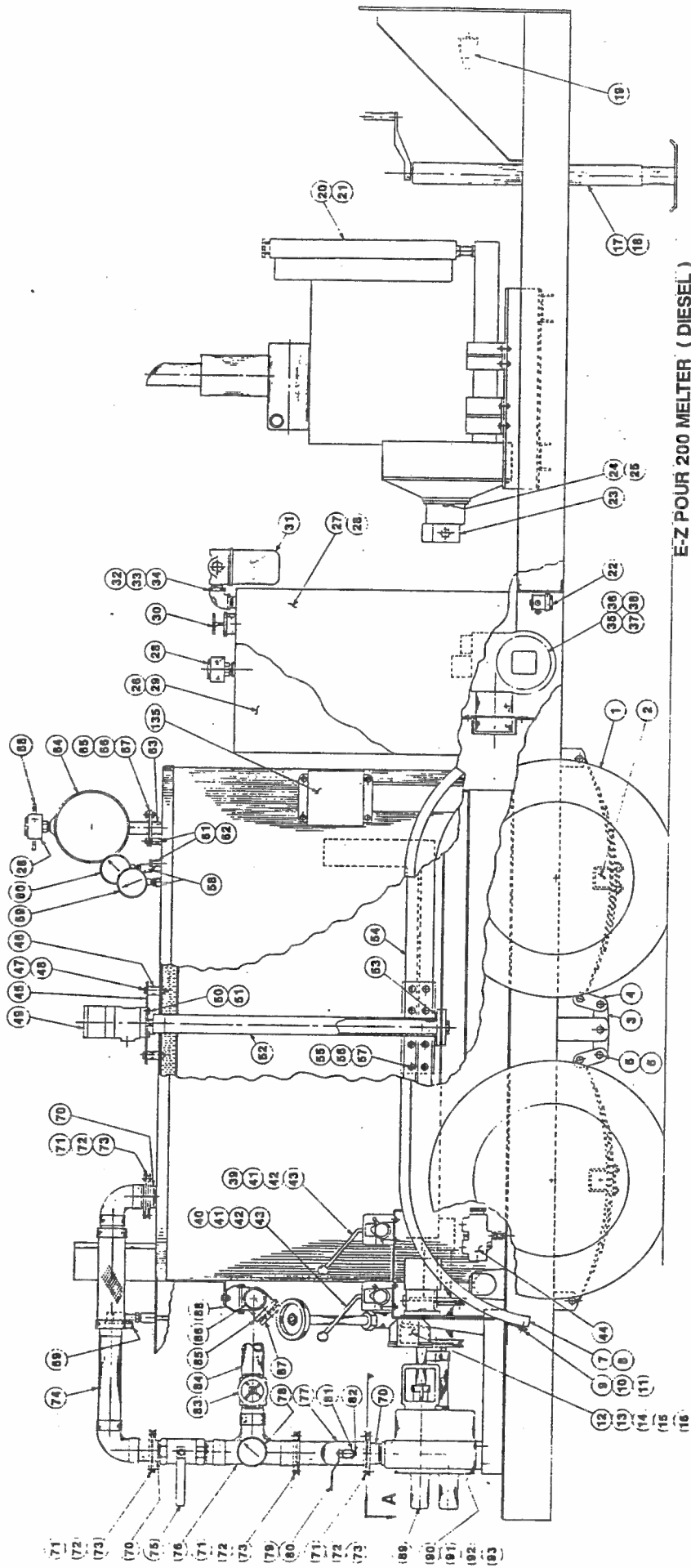

E-Z POUR 200 MELTER (DIESEL)
W/ PUMP APPLICATOR

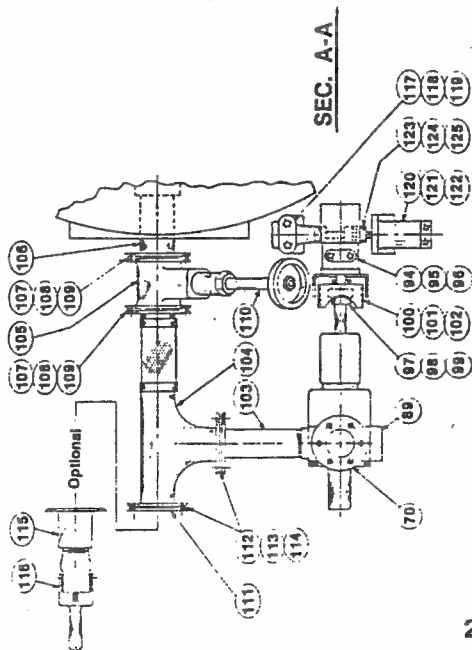
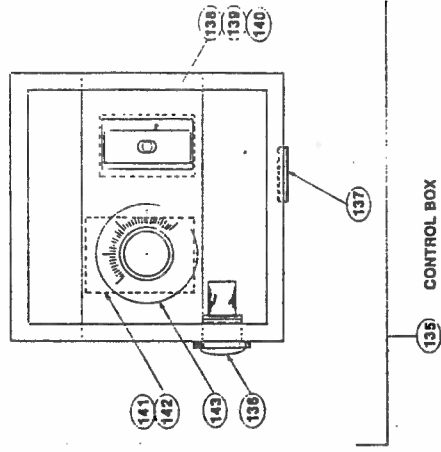
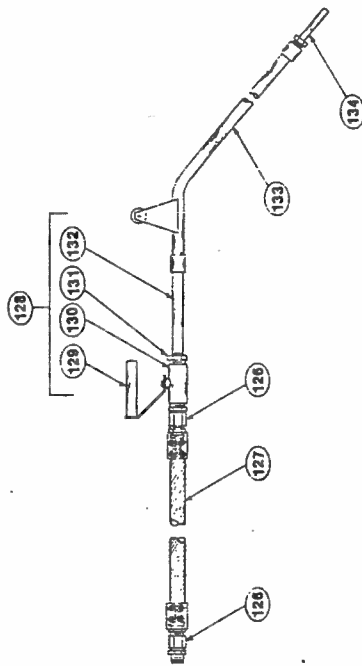

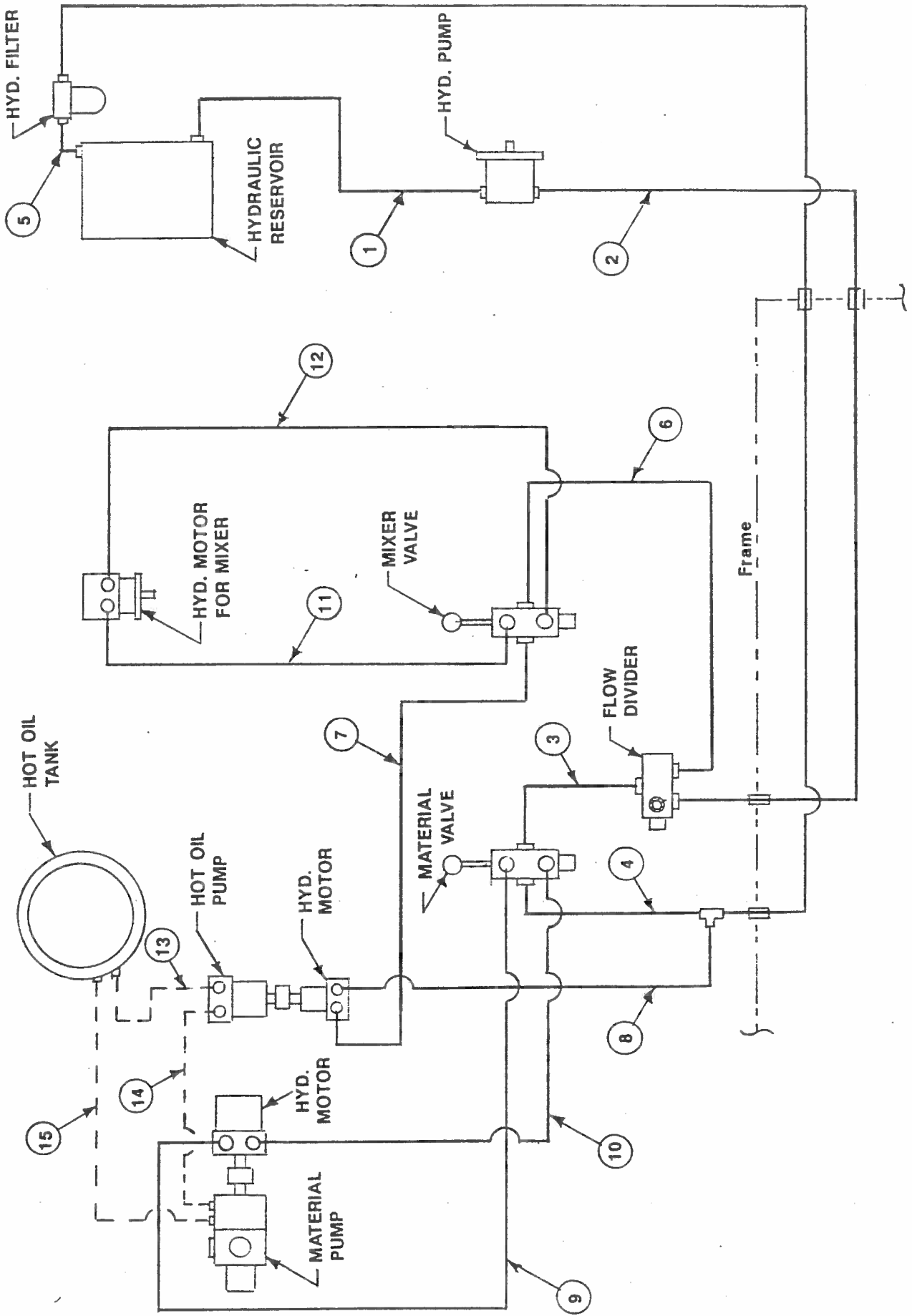

HYDRAULIC PIPING DIAGRAM
E-Z Pour 200 Meiter (Diesel)
 (W/ PUMP APPLICATOR)

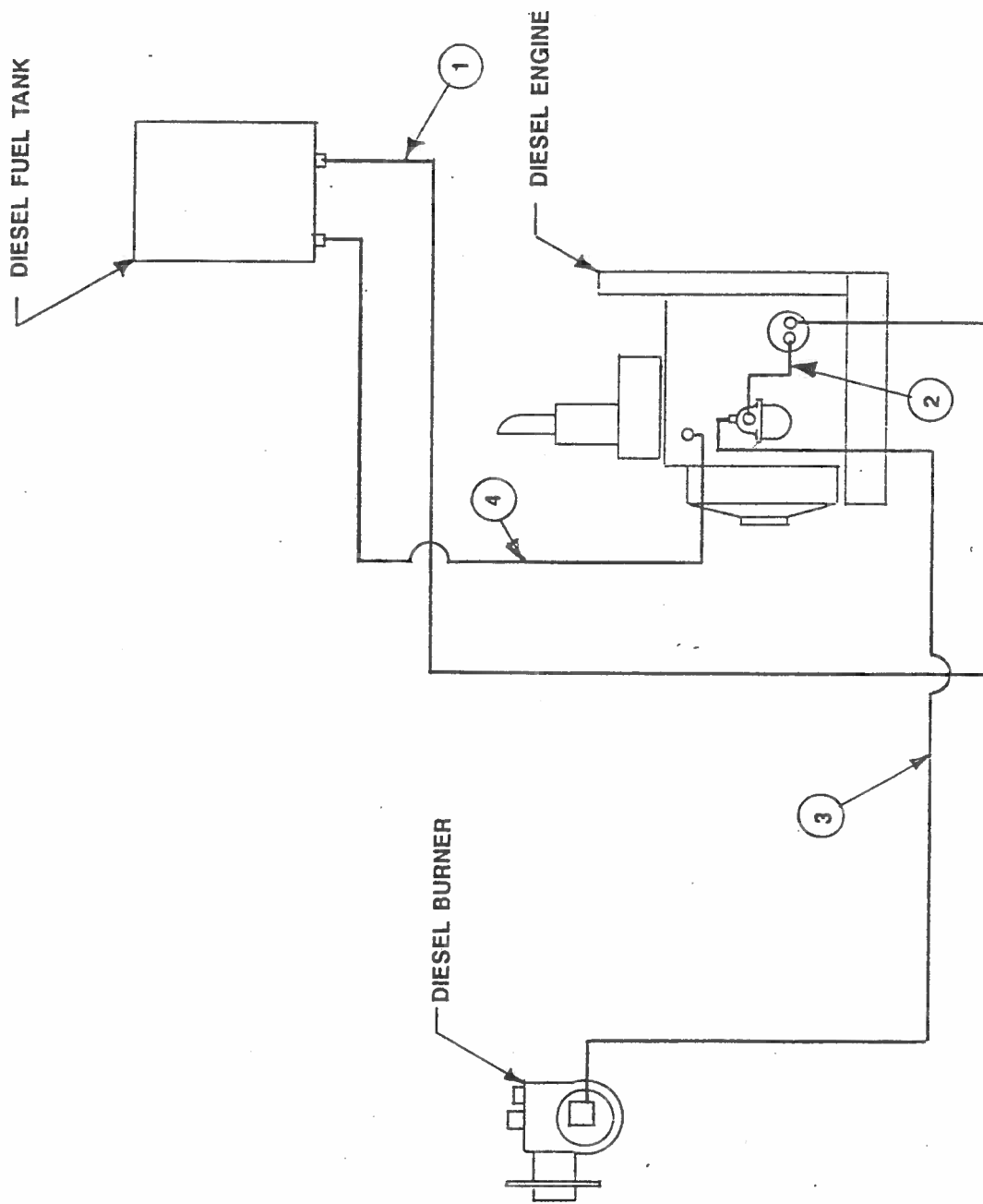

DIESEL PIPING DIAGRAM

E-Z Pour 200 Melter

(W/ PUMP APPLICATOR)

REVISIONS		DATE	REV	BY	DESCRIPTION

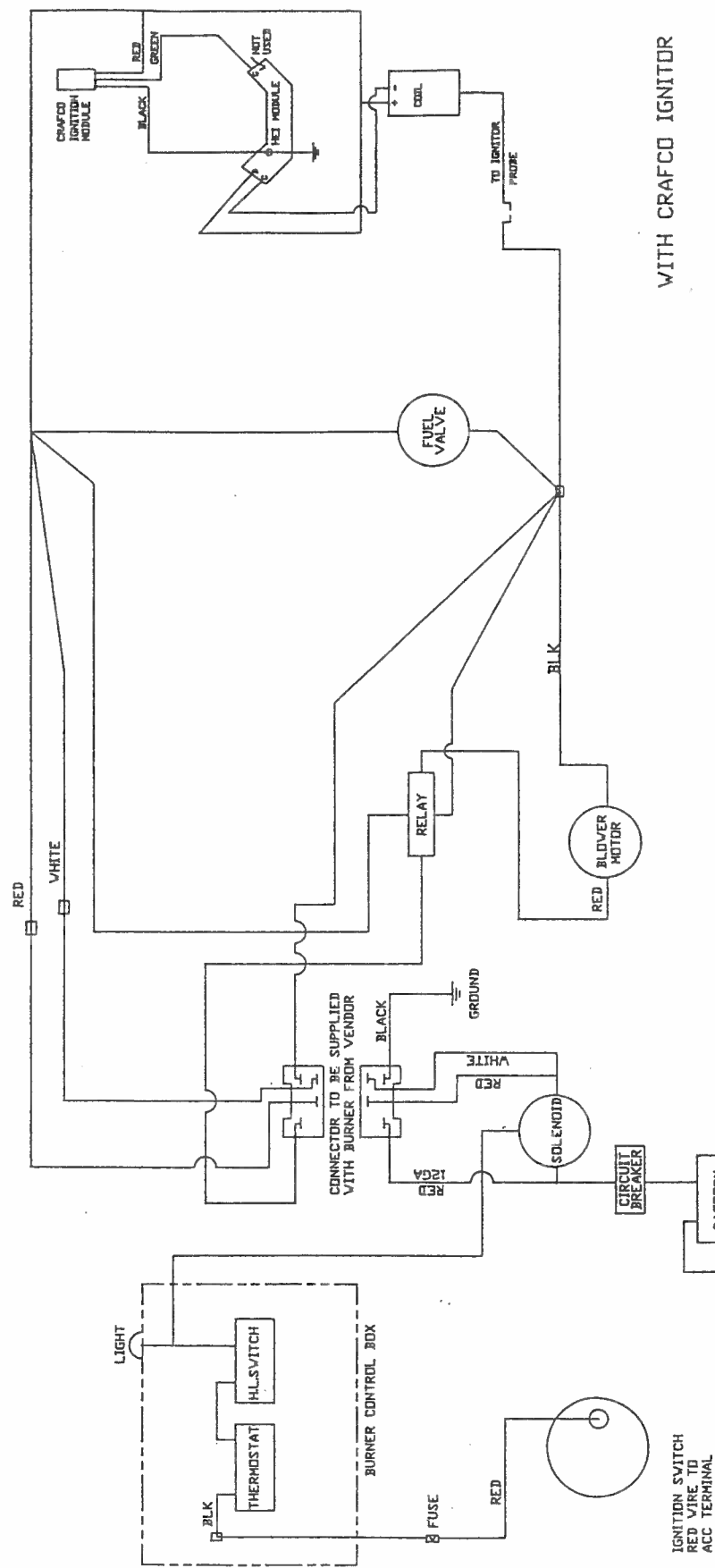

WITH CRAFCO IGNITOR

NOTES:
1. □ WIRE NUT

SIGNATURES		DATES	
DRAWN BY: BCHAWE		11/11/92	
<small>APPROVED: (Signature) THIS SCHEMATIC IS THE PROPERTY OF CRAFCO INC. IT IS TO BE USED FOR THE DESIGN, CONSTRUCTION, AND REPAIR OF THE EQUIPMENT ONLY. IT IS NOT TO BE REPRODUCED OR TRANSMITTED IN ANY FORM OR BY ANY MEANS, ELECTRONIC OR MECHANICAL, INCLUDING PHOTOCOPYING, RECORDING, OR BY ANY INFORMATION STORAGE AND RETRIEVAL SYSTEM. PERMISSION IS GRANTED TO MAKE A COPY OF THIS SCHEMATIC FOR PERSONAL USE ONLY. ALL RIGHTS RESERVED. © 1992 CRAFCO INC. ANGLES & 1/27</small>			
TITLE		SIZE	REV.
BURNER SCHEMATIC W/ FLAME SHUTDOWN		B	0
SCALE		SIZE	REV.
NONE		41935F	0
SHEET		DO NOT SCALE DRAWING SHEET 1 OF 1	

REVISIONS	
DATE	DESCRIPTION

NOTES:
1. WIRES TO BE TINNED BEFORE TERMINALS ARE ATTACHED.

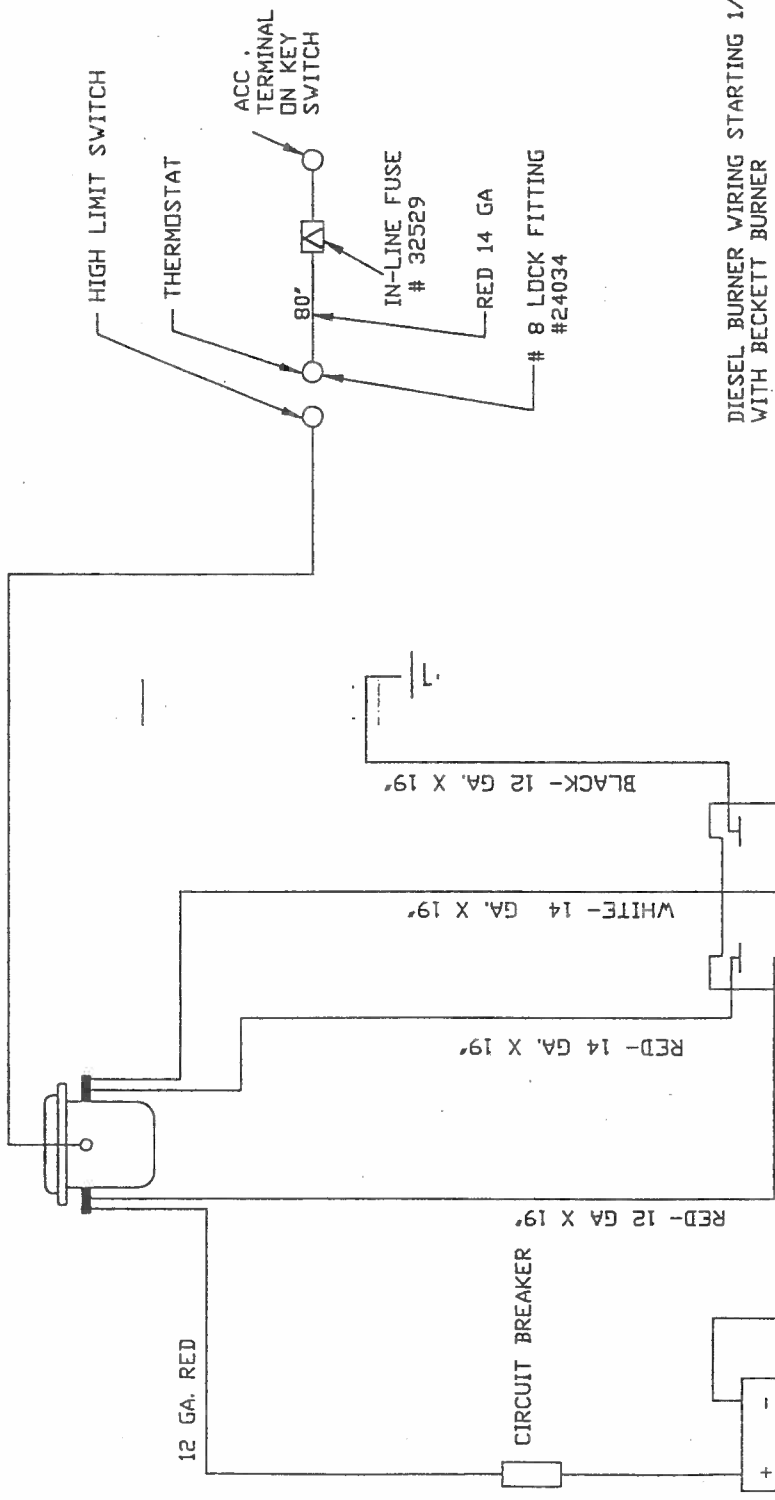

SIGNATURES		DATES	
			1/23/93
<small>APPROVED FOR THE MANUFACTURER'S REPRESENTATIVE: CRAFCO INC. ALL RIGHTS RESERVED. THIS DRAWING IS THE PROPERTY OF CRAFCO INC. AND SHALL BE KEPT IN CONFIDENCE. NO PART OF THIS DRAWING IS TO BE REPRODUCED OR TRANSMITTED IN ANY FORM OR BY ANY MEANS, ELECTRONIC OR MECHANICAL, INCLUDING PHOTOCOPYING, RECORDING, OR BY ANY INFORMATION STORAGE AND RETRIEVAL SYSTEM, WITHOUT THE WRITTEN PERMISSION OF CRAFCO INC. TOLERANCES (UNLESS OTHERWISE SPECIFIED): DIMENSIONS: .0005 ANGLES: 1/2° MATERIAL: </small>			
TITLE		STOCK #	
WIRING WITH INTERNAL CIRCUIT BREAKER			
REV. NO.		SCALE	
B	25288	NONE	
SHEET NO.		SHEET 1 OF 1	

DIESEL BURNER WIRING STARTING 1/23/93 WITH BECKETT BURNER

CRAFCO INC.